

for 4 ... 20 mA two-wire technology

- Low operating cost
- Compact design
- Well-proven technology
- Robust and environmentally ruggedized
- Wide operating temperature range
-40 ... 85 °C (-40 ... 185 °F)
- Easy to commission, “single pushbutton”
operating philosophy
- Mechanical position indicator
- ATEX, FM, CSA, GOST and IECEx approvals
- For SIL2 safety loops



HART
COMMUNICATION PROTOCOL

Compact, well-proven, and flexible

ABB

Contents

1	Description	3
1.1	Pneumatics.....	3
1.2	Operation.....	3
1.3	Communication	3
1.4	Inputs and outputs.....	3
1.5	Modular design.....	3
2	Mounting versions	5
2.1	To linear actuators in accordance with the standard	5
2.2	To rotary actuators in accordance with the standard	5
2.3	Integral mounting to control valves	5
2.4	Special actuator-specific mounting	5
3	Operation	7
3.1	General.....	7
3.2	Operator panel	8
4	Communication	9
4.1	DTM.....	9
4.2	LKS adapter (RS-232 interface converter).....	9
4.3	FSK Modem	9
5	Specifications	10
5.1	Input.....	10
5.2	Output.....	10
5.3	Travel.....	10
5.4	Air supply.....	10
5.5	Transmission data and influences.....	10
5.6	Environmental capabilities	11
5.7	Housing	11
5.8	Safety Integrity Level.....	11
5.9	Explosion protection.....	12
5.10	Options	13
5.11	Accessories	14
6	Electrical connections	15
7	Dimensions	16
8	Ordering information	19

1 Description

The TZIDC is an electronically configurable positioner with communication capabilities designed for mounting to pneumatic linear or rotary actuators. It features a small and compact design, a modular construction, and an excellent cost-performance ratio.

Fully automatic determination of the control parameters and adaptation to the final control element yield considerable time savings and an optimal control behavior.

1.1 Pneumatics

An I/P module with subsequent pneumatic amplifier is used to control the pneumatic actuator. The well-proven I/P module proportionally converts the permanent electrical setpoint signal from the CPU into a pneumatic signal used to adjust a 3/3-way valve.

The air flow for pressurizing or depressurizing the actuator is continuously adjusted. As a result, excellent control is achieved. When reaching the set point, the 3/3-way valve is closed in center position to minimize the air consumption.

Four different pneumatics versions are available: for single-acting or double-acting actuators, each with "fail-safe" or "fail-freeze" function.

1.1.1 "Fail-safe" function

If the electrical power supply fails, the positioner output 1 is depressurized, and the pneumatic actuator's return spring moves the valve to the defined safe position. In case of a double-acting actuator the second output 2 is additionally pressurized.

1.1.2 "Fail-freeze" function

If the electrical power supply should fail, the positioner output 1 (and 2, if applicable) is closed and the pneumatic actuator stops ("freezes") the valve in the current position. If compressed air supply should fail, the positioner depressurizes the actuator.

1.2 Operation

The positioner has a built-in operating panel providing a 2-line LCD and 4 pushbuttons for optimal local configuration, commissioning and operational monitoring.

Alternatively, the appropriate configuration program and the available communication option can be used.

1.3 Communication

The standard TZIDC model has a local communication interface (LKS connector). Additionally, a "HART communication" option for communication via the 20 mA signal is available. Both communications are based on the HART Protocol.

1.4 Inputs and outputs

In addition to its input for the analog position set point the TZIDC positioner is equipped with a digital input which can be used to activate various protective functions in the device via the process control system. A digital output allows you to output collective alarms or fault messages.

1.5 Modular design

The TZIDC basic model can be enhanced at any time by retrofitting optional equipment. Option modules for analog or digital position feedback or a shutdown-module can be installed. Additionally, a mechanical position indicator, proximity switches or 24 V microswitches are available for indicating the position independently of the mother board function.

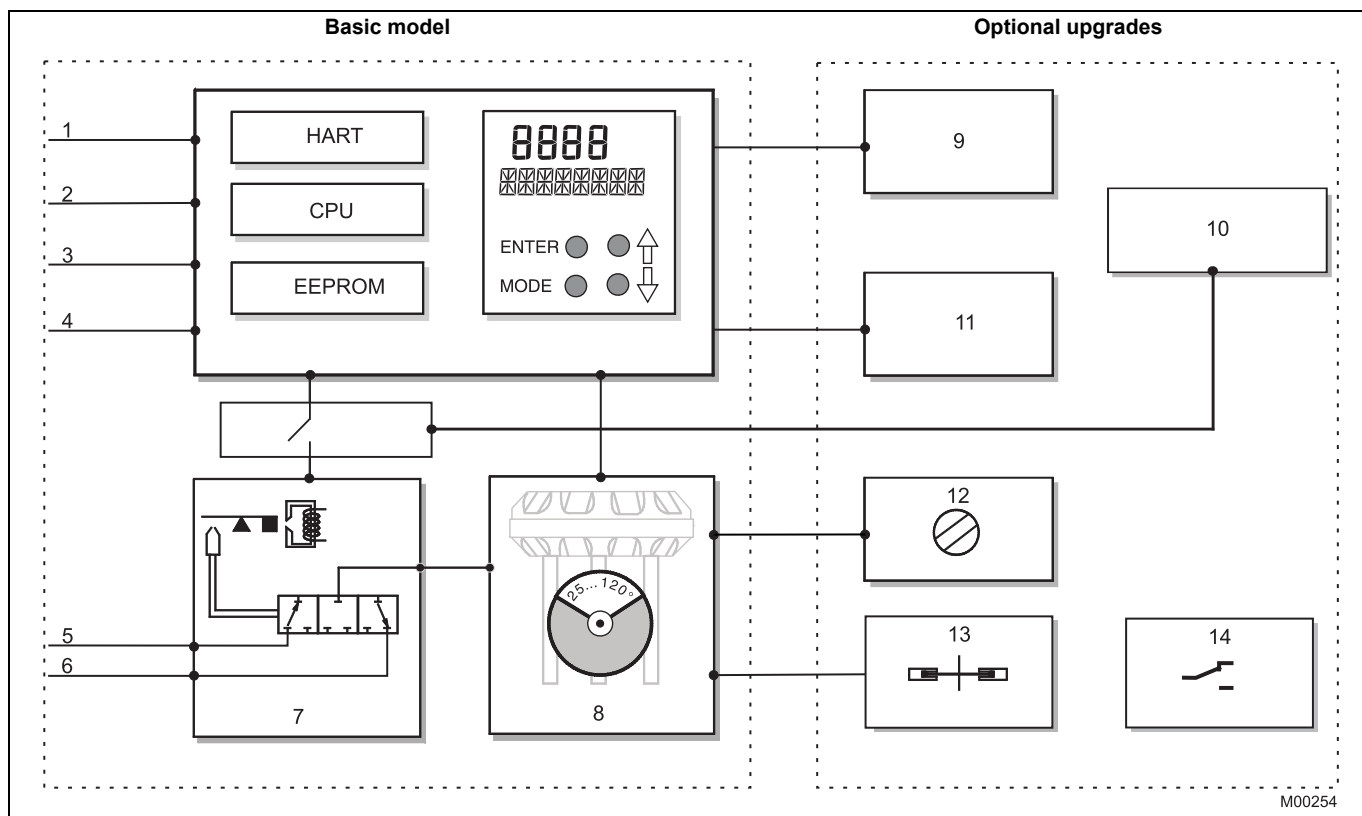

Fig. 1: TZIDC schematic diagram

Basic model

- 1 LKS plug
- 2 Setpoint signal 4 ... 20 mA
- 3 Digital input
- 4 Digital output DO
- 5 Supply, 1.4 ... 6 bar (20 ... 90 psi)
- 6 Exhaust
- 7 I/P module with 3/3-way valve
- 8 Position sensor (optional up to 270° rotation angle)

Optional upgrades

- 9 Plug module for analog feedback (4 ... 20 mA)
- 10 Plug-in module for safety shutdown (forced depressurization)
- 11 Plug module for digital feedback
- 12 Installation kit for mechanical position indicator
- 13 Installation kit for digital feedback with proximity switches
- 14 Installation kit for digital feedback with 24 V microswitches



Important

With optional upgrades either the "Installation kit for digital feedback with proximity switches" (13) or the "Installation kit for digital feedback with microswitches 24 V" (14) can be used.

In both cases, the "mechanical position indicator" (8) must be installed.

2 Mounting versions

2.1 To linear actuators in accordance with the standard

Lateral attachment is in accordance with DIN / IEC 534 (lateral attachment to NAMUR). The required attachment kit is a complete set of attachment material, but does not include the screwed pipe connections and air pipes.

2.2 To rotary actuators in accordance with the standard

This attachment is designed for mounting according to the standard VDI/VDE 3845. The attachment kit consists of a console with mounting screws for mounting on a rotary actuator. The adapter for coupling the positioner feedback shaft to the actuator shaft has to be ordered separately. Screwed pipe connections and air pipes have to be provided on site.

2.3 Integral mounting to control valves

The TZIDC positioner featuring standard pneumatic action is available as an option for integral mounting.

The required holes are found at the back of the device.

The benefit of this design is that the point for mechanical stroke measurement is protected and that the positioner and actuator are linked internally. No external tubing is required.

2.4 Special actuator-specific mounting

In addition to the mounting methods described above, there are special actuator-specific attachments.

Please contact us for details.

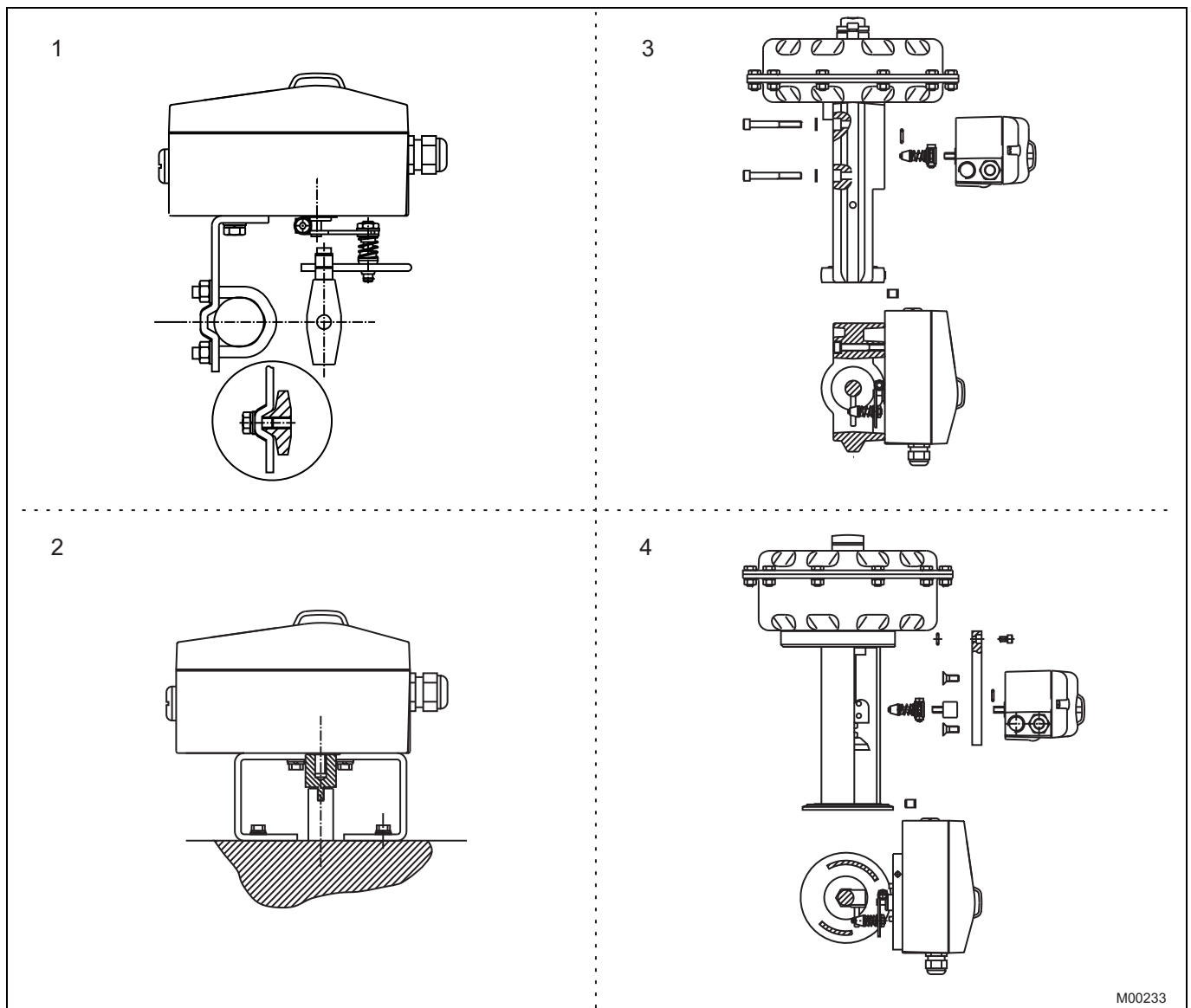

Fig. 2: Mounting options

- 1 Mounting to linear actuators acc. to DIN / IEC 534
- 2 Mounting to rotary actuators to VDI / VDE 3845

- 3 Integral mounting to control valves
- 4 Integral mounting to control valves by using an adapter panel

3 Operation

3.1 General

Microprocessor-based position control in the TZIDC provides for optimal results. The positioner features high-precision control functions and high operational reliability. Due to their elaborate structure and easy accessibility, the device parameters can be quickly adapted to the respective application.

The total range of parameters includes:

- Operating parameters
- Adjustment parameters
- Monitoring parameters
- Diagnosis parameters
- Maintenance parameters

3.1.1 Operating parameters

The following operating parameters can be set manually if required:

Setpoint Signal

Signal min. 4 mA, max. signal 20 mA (0 ... 100 %)
freely selectable for split-range operation
min. range 20 % (3.2 mA)
recommended range > 50 % (8.0 mA)

Action (setpoint signal)

Increasing: Setpoint Signal 4 ... 20 mA = position 0 ... 100 %
Decreasing: Setpoint Signal 20 ... 4 mA = position 0 ... 100 %

Characteristic curve (travel = f {setpoint signal})

Linear, equal percentage 1:25 or 1:50 or 25:1 or 50:1 or freely configurable with 20 reference points.

Travel limit

The positioning travel, i.e. the stroke or angle of rotation, can be reduced as required within the full range of 0 ... 100 %, provided that a minimum value of 20 % is observed.

Shut-off function

This parameter can be set separately for each end position. When the respective configured limit value is exceeded, the shut-off function causes immediate travel of the actuator until reaching the set end position.

When the shut-off value is set to "0", the position is further controlled, even in the respective end position.

Travel time prolongation

This function can be used to increase the max. travel time for full travel. This time parameter can be set separately for each direction.



Important

This function can only be used with the pneumatics with the safety function "fail-safe".

Switching points for the position

This parameter allows you to define two position limits for signaling (see option "Module for digital position feedback").

Digital output

The alarms generated in the TZIDC positioner can be polled via the digital output as a collective alarm.

The desired information can be selected via the operator panel or remotely via the configuration program.

The output can be set to "active high" or "active low", as required.

Digital input

For the digital input, one of the following safety options can be selected. You may use the operator's panel or configuration program to select an option.

- No function (default)
- Move to 0 % position
- Move to 100 % position
- Hold previous position
- disable local configuration
- Disable local configuration and operation
- Disable any access (no local or remote access via a PC)

The selected function is activated once the 24 V DC signal is no longer applied (< 11 V DC).

3.1.2 Adjustment parameters

The TZIDC positioner has a special function for automatic adjustment of the parameters.

Additionally, the control parameters can be set automatically (in adaptive control mode) or manually to optimally adapt them to the process requirements.

Tolerance band

Upon reaching the tolerance band, the position is slowly re-adjusted until the dead band has been reached.

Dead band (sensitivity)

When reaching the dead band, the position is held. The factory setting for this parameter is 0,1 %.

Actuator spring action

Selection of the sensor shaft rotating sense (looking into the open case), if the valve is moved to the safe position by the actuator spring (actuator is depressurized via Y1 / OUT1).

For double-acting actuators the actuator spring action corresponds to pressurizing the pneumatic output (OUT2).

Display 0 ... 100 %

Adjusting the display (0 ... 100%) according to the direction of action for opening or closing the valve.

3.1.3 Monitoring parameters

Various functions for permanent operational monitoring are implemented in the TZIDC operating program. The following states will be detected and indicated, e.g.:

- 4 ... 20 mA setpoint signal out of range
- position out of the adjusted range
- positioning time-out (adjustable time parameter)
- position controller inactive
- counter limits (settable in the diagnosis phase) exceeded

While automatic commissioning is in progress, the current state is continuously indicated on the integrated LCD.

During operation, the LCD shows the most important process variables:

- current position (in %),
- malfunctions, alarms, messages (as code)

Access to extended monitoring parameters is possible via HART communication and the DTM.

3.1.4 Diagnosis parameters

The diagnosis parameters of the TZIDC program inform the operator about the operating conditions of the valve.

From this information the operator can derive which maintenance works are required, and when.

Additionally, limit values can be defined for these parameters. When they are exceeded, an alarm is reported.

The following values are e.g. determined:

- Number of movements performed by the valve
- Total travel

The diagnosis parameters and limit values can be called up, set, and reset via HART communication, using the configuration program.

3.2 Operator panel

The TZIDC positioner's operator panel with four pushbuttons allows for

- operational monitoring
- manual control
- configuration
- fully automatic commissioning

The operator panel is protected by a cover which avoids unauthorized access to the operating elements.

3.2.1 Single-button commissioning

Commissioning the TZIDC positioner is especially easy. The standard Autoadjust function for automatic adaptation of the device parameters can be started by simply pressing a single front panel button, and without knowing parameterization details.

Depending on the selected actuator type (linear or rotary), the displayed zero position is automatically adapted:

- for linear actuators counter-clockwise (CTCLOCKW)
- for rotary actuators clockwise (CLOCKW).

Besides this standard function, a customized "Autoadjust" function is available. The function is launched either via the operator's panel or HART communication.

3.2.2 Display

The information indicated by the 2-line LC display is permanently updated and adapted during operation, to inform the operator in an optimal way.

During control operation (control with or without adaptation) the following TZIDC data can be called up by pressing the pushbuttons briefly:

- Up button: Current setpoint (mA)
- Down button: Temperature in device
- Up + Down buttons: Current control deviation



Fig. 3: TZIDC with removed cover, view of the operator panel

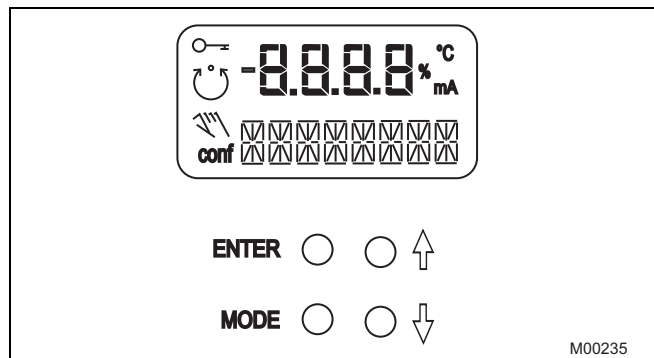

Fig. 4: TZIDC operating elements and display

4 Communication

4.1 DTM

The DTM (Device Type Manager) for TZIDC is based on the FDT / DTM technology (FDT 1.2) and can be integrated in a process control system or loaded in a PC with the DSV401 (SMART VISION) program. This allows you to work with the same user interface in the commissioning phase, during operation, and for service tasks for monitoring the device, setting parameters, and uploading data.

Communication is based on the HART protocol. It occurs via a local interface connection (LKS) or in frequency-modulated mode using an FSK-modem connected at any chosen point of the 20 mA signal line. Communication has no effect on operation. Newly set parameters are saved in the non-volatile memory directly upon the download into the device, and become active immediately.

4.2 LKS adapter (RS-232 interface converter)

You can easily connect your TZIDC positioner to a PC, e.g., in the workshop or in the commissioning phase, by using the positioner's LKS adapter (LKS = local communication interface).

An RS-232 interface converter adapts the signals on the serial PC port to the level of the positioner's LKS.

4.3 FSK Modem

The FSK modem establishes a digital frequency-modulated communication (Frequency Shift Keying) with the TZIDC positioner.

Tapping is possible at any chosen point of the 20 mA signal line.

We recommend that you use an electrically isolated FSK modem. It is bus-compatible when used with isolating amplifiers. Even connecting explosion-protected field devices is possible, on condition that the FSK modem is run outside the hazardous area.

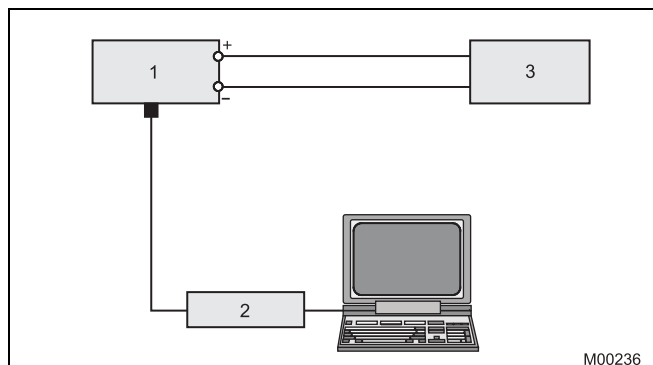

Fig. 5: Local communication via LKS adapter

- 1 TZIDC
- 2 LKS adapter
- 3 Controller

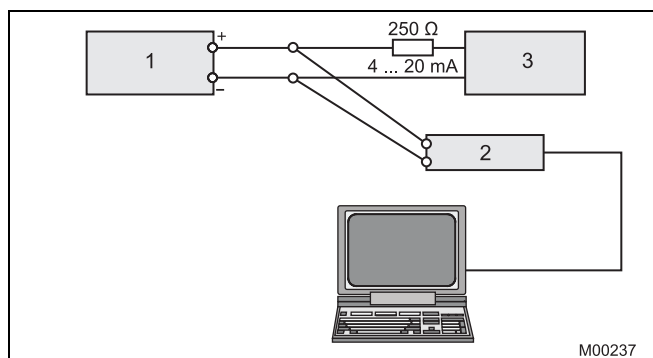

Fig. 6: HART communication with FSK modem via 20 mA signal line

- 1 TZIDC
- 2 FSK modem
- 3 Controller

5 Specifications

5.1 Input

Setpoint signal (two-wire technology)

Nominal range	4 ... 20 mA
Split range configuration between	20 ... 100 % of the nominal range
Max.	50 mA
Min.	3.6 mA
Starting at	3.8 mA
Load voltage at 20 mA	9.7 V
Impedance at 20 mA	485 Ω

Digital input

Control voltage	0 ... 5 V DC logical switching state "0" 11 ... 30 V DC logical switching state "1"
Current	max. 4 mA

5.2 Output

Compressed air output

Range	0 ... 6 bar (0 ... 90 psi)
Air capacity	5.0 kg/h = 3.9 Nm ³ /h = 2.3 sfc at 1.4 bar (20 psi) supply pressure 13 kg/h = 10 Nm ³ /h = 6.0 sfc at 6 bar (90 psi) supply pressure
Output function	For single or double-acting actuators, air is vented from actuator or actuator is blocked in case of (electrical) power failure
Shut-off values	End position 0 % = 0 ... 45 % End position 100 % = 55 ... 100 %

Digital output (control circuit to DIN 19234 / NAMUR)

Supply voltage	5 ... 11 V DC
Current > 0.35 mA ... < 1.2 mA	Switching state logical "0"
Current > 2.1 mA	Switching state logical "1"
Effective direction (configurable)	normally logical "0" or logical "1"

5.3 Travel

Rotation angle

Used range	25 ... 120° (rotary actuators, optional 270°) 25 ... 60° (linear actuators)
Travel limit	Min. and max. limits, freely configurable between 0 ... 100 % of total travel (min. range > 20 %)
Travel time prolongation	Range of 0 ... 200 s, separately for each direction
Dead band time limit	Setting range 0 ... 200 s (monitoring parameter for control until the deviation reaches the dead band)

5.4 Air supply

Instrument air

free of oil, water and dust to DIN/ISO 8573-1. Pollution and oil content according to Class 3 (purity: max. particle size = 5 μm, max. particle density = 5 mg / m³; oil content: max. concentration = 1 mg / m³; pressure dew point: 10 K below operating temperature)

Supply pressure

1.4 ... 6 bar (20 ... 90 psi)



Important

Do not exceed the maximum operating pressure of the actuator!

Air consumption

< 0.03 kg/h / 0.015 scfm (independent of supply pressure)

5.5 Transmission data and influences

Output Y1

Increasing	Increasing setpoint signal 0 ... 100 % Increasing pressure at output
Decreasing	Increasing setpoint signal 0 ... 100 % Decreasing pressure at output

Action (setpoint signal)

Increasing	Signal 4 ... 20 mA = actuator position 0 ... 100 %
Decreasing	Signal 20 ... 4 mA = actuator position 0 ... 100 %

Characteristic curve (travel = f {setpoint signal})

Linear, equal percentage 1:25 or 1:50 or 25:1 or 50:1 and freely configurable with 20 reference points.

Deviation	≤ 0,5 %
Tolerance band	0.3 ... 10 %, adjustable
Dead band	0.1 ... 10 %, adjustable
Resolution (A/D conversion)	> 16000 steps
Sample rate	20 ms
Influence of ambient temperature	≤ 0.5 % per 10 K
Influence of vibration	≤ 1 % to 10 g and 80 Hz

Seismic vibration

Meets requirements of DIN / IEC 68-3-3 Class III for strong and strongest earthquakes.

Influence of mounting orientation

Not measurable.

Complies with the following directives

- EMC Directive 2004/108/EC as of December 2004
- EC Directive for CE conformity marking

Communication

- HART Protocol 5.9
- Local connector for LKS (not in Ex area)
- HART communication via 20 mA signal line with (optional) FSK modem

5.6 Environmental capabilities

Ambient temperature

For operation, storage and transport: -40 ... 85 °C (-40 ... 185 °F)
When using proximity switches
SJ2-S1N (NO): -25 ... 85 °C (-13 ... 185 °F)

Relative humidity

Operational (with closed housing
and air supply switched on): 95 % (annual average),
condensation permissible
Transport and storage: 75 % (annual average), non-
condensing

5.7 Housing

Material / protection

Aluminum, protection class IP 65 (optional IP 66) / NEMA 4X

Surface / color

Electrostatic dipping varnish with epoxy resin, stove-hardened.
Case varnished black, RAL 9005, matte, housing cover Pantone
420.

Electrical connections

Screw terminals: Max. 1.0 mm² (AWG 17) for options
Max. 2.5 mm² (AWG 14) for bus connector



Important

Do not expose the terminals to strain.

Cable entry: 2 cable glands 1/2-14 NPT or M20 x 1.5
(1 x with cable gland and 1 x with pipe plug)

Pneumatic connections

Threads G 1/4 or 1/4-18 NPT

Weight

1.7 kg (3.75 lb)

Mounting orientation

any

5.8 Safety Integrity Level



Important

Applies to applications with single-acting and depressurizing
pneumatics.

The positioner TZIDC / TZIDC-200 and the emergency shutdown
module for meet the requirements regarding:

- functional safety acc. to IEC 61508
- explosion protection (depending on the model)
- electromagnetic compatibility in accordance with EN 61000

Without the input signal, the pneumatic module in the positioner vents
the drive and the installed spring in it moves the valve in a
predetermined end position (OPEN or CLOSED).

SIL specific safety-related characteristics:

Device	SFF	PFDav	$\lambda_{dd} + \lambda_s$	λ_{du}
TZIDC / TZIDC-200 as shutdown module	94 %	$1.76 * 10^{-4}$	718 FIT	40 FIT
TZIDC / TZIDC-200 with supply current 0 mA	94 %	$1.76 * 10^{-4}$	651 FIT	40 FIT

For details refer to the Management Summary in the SIL-Safety
Instructions 37/18-79XA.

5.9 Explosion protection



Important

The values indicated here are taken from the respective approval certificates.
Always observe the specifications and supplements in the certificates.
(see operating instructions).

FM J.I. 3005029 (3610, 3611)

Intrinsically safe
Class I, Div. 1 Grp. A-B-C-D
Class II, Div. 1 Grp. E-F-G
CL III, Div. 1
Non-incendive, suitable for use in Div. 2 environment

CSA Certification 1052414

Intrinsically safe; Enclosure 4X; T4, max. 85 °C
Class I, Div. 1 Grp. A-B-C-D
Class II, Div. 1 Grp. E-F-G
CL III, Div. 1

Non-incendive; Enclosure 4X, max. 85 °C
Class I, Div. 2 Grp. A-B-C-D
Class II, Div. 2 Grp. E-F-G
CL III

ATEX / GOST Russia / GOST Ukraine

II 2G EEx ib IIC T6
Prototype test certificate: TÜV 98 ATEX 1370 X
Type: Intrinsically safe equipment
Device class: II 2G (EEx ib IIC)
Temperature class: T4, T5, T6
Permissible ambient temperature: T4: $-40\text{ °C} \leq T_{\text{amb}} \leq 85\text{ °C}$
T5: $-40\text{ °C} \leq T_{\text{amb}} \leq 50\text{ °C}$
T6: $-40\text{ °C} \leq T_{\text{amb}} \leq 35\text{ °C}$

ATEX

II 2G EEx ib IIC T6
II 2G EEx ia IIC T6
Prototype test certificate: TÜV 04 ATEX 2702 X
Type: Intrinsically safe equipment
Device class: II 2G (EEx ib IIC)
II 2G (EEx ia IIC)
Temperature class: T4, T5, T6
Permissible ambient temperature: T4: $-40\text{ °C} \leq T_{\text{amb}} \leq 85\text{ °C}$
T5: $-40\text{ °C} \leq T_{\text{amb}} \leq 50\text{ °C}$
T6: $-40\text{ °C} \leq T_{\text{amb}} \leq 35\text{ °C}$

ATEX

Prototype test certificate: TÜV 02 ATEX 1943 X
Type: Explosion-proof equipment (Zone 2)
Device class: II 3G (EEx n A II)
Temperature class: T4, T5, T6
Permissible ambient temperature: T4: $-40\text{ °C} \leq T_{\text{amb}} \leq 85\text{ °C}$
T5: $-40\text{ °C} \leq T_{\text{amb}} \leq 65\text{ °C}$
T6: $-40\text{ °C} \leq T_{\text{amb}} \leq 50\text{ °C}$

II 3G EEx n A II T6

ATEX

Prototype test certificate: TÜV 04 ATEX 2702 X
Type: Intrinsically safe equipment
Device class: II 2 D (IP 6X)

II 2 D IP 6X T 51 °C

Permissible housing surface temperature	Permissible ambient temperature (II D)
T81 °C	-40 ... 70 °C
T61 °C	-40 ... 50 °C
T51 °C	-40 ... 35 °C

IECEX

Prototype test certificate: IECEX TUN 04.0015X,
Issue no.: 0
Type: Intrinsically safe
Temperature class: T4, T5, T6
Permissible ambient temperature: T4: $-40\text{ °C} \leq T_{\text{amb}} \leq 85\text{ °C}$
T5: $-40\text{ °C} \leq T_{\text{amb}} \leq 50\text{ °C}$
T6: $-40\text{ °C} \leq T_{\text{amb}} \leq 35\text{ °C}$

Ex ib IIC T6

5.10 Options

Module for analog position feedback ¹⁾

Signal range	4 ... 20 mA (configurable split ranges)
Supply, 2-wire circuitry	24 V DC (10 ... 30 V DC) 48 V DC (20 ... 48 V DC, no ignition protection)
Characteristic curve (configurable)	Rising or falling
Deviation	< 1 %

i Important
Without a signal from the positioner (e.g., "no power" or "initializing") the module sets the output to > 20 mA (alarm level)

Module for digital position feedback ¹⁾

Two switches for digital position feedback (position adjustable within the range of 0 ... 100 %, ranges cannot overlap)

Current circuits acc. to DIN 19234 / NAMUR	
Supply voltage	5 ... 11 V DC
Signal current < 1.2 mA	Switching state logical "0"
Signal current > 2.1 mA	Switching state logical "1"
Direction of action	normally logical "0" or logical "1" (configurable)

Module for the emergency shutdown function ²⁾

Supply voltage	24 V DC (20 ... 30 V DC) (galvanically isolated from input signal)
Safe position is activated when	Voltage < 5 V
SIL	See "Safety Integrity Level"

A separate 24 V DC signal is normally applied to the emergency shutdown module, which connects through the signal from the microprocessor to the I/P module. When the 24 V DC signal is interrupted, the I/P module executes the respective safety function, depending on the mechanical construction.

The positioner output 1 is depressurized, and the valve is moved to the safe position. In case of a double-acting actuator the second output 2 is additionally pressurized.

i Important
The emergency shutdown module can only be used with pneumatics with the safe position "fail-safe".

The emergency shutdown module works independently of the mother board, i.e. all information from the final control element is available in the supervisory process control system at any time.

- 1) The module for analog position feedback and the module for digital position feedback plug in separate slots and can be used together.
- 2) The module for the emergency shutdown function uses the same space as the module for analog feedback and the module for analog or digital feedback and cannot be plugged in and run together with any of them.

Digital position feedback with proximity switches

Two proximity switches for independent position signaling, Switching points adjustable between 0 ... 100 %

Current circuits acc. to DIN 19234 / NAMUR

Supply voltage	5 ... 11 V DC
Signal current < 1.2 mA	Switching state logical "0"
Signal current > 2.1 mA	Switching state logical "1"

Direction of action (logical state)

Proximity switch	Position			
	< Lim. 1	> Lim. 1	< Lim. 2	> Lim. 2
SJ2-SN (NC)	0	1	1	0
SJ2-S1N (NO)	1	0	0	1

i Important
When using proximity switch SJ2_S1N (NO), the TZIDC positioner may only be used at an ambient temperature range -25 ... 85 °C (-13 ... 185 °F).

Digital position feedback with 24 V microswitches

Two microswitches for independent position signaling. Switching points can be adjusted from 0 ... 100 %.

Voltage	max. 24 V AC / DC
Load rating	max. 2 A
Contact surface	10 µm Gold (AU)

Mechanical position indicator

Indicator disk in enclosure cover linked with positioner feedback shaft.

i Important
These options are also available for retrofitting by Service.

5.11 Accessories

Mounting material

- Attachment kit for linear actuators to DIN/IEC 534 / NAMUR
- Attachment kit for rotary actuators to VDI / VDE 3845
- Attachment kit for integral mounting to control valves
- Attachment kit for actuator-specific attachment upon request

Pressure gauge block

- With pressure gauges for supply and output pressure.
- Pressure gauges with housing \varnothing 28 mm
- Aluminum connection block in black
- Installation material in black for mounting to TZIDC

Filter regulator

All metal version in brass, varnished black, bronze filter element, (40 μ m) , with condensate drain.

max. pre-pressure 16 bar (232 psi), output adjustable to 1.4 ... 6 bar (20.31 ... 90 psi).



Important

The filter regulator may only be installed in combination with the pressure gauge block (accessory).

PC adapter for communication

LKS adapter for plug-in connection to TZIDC

FSK modem for HART communication

PC software for remote configuration and operation

DSV401 (SMART VISION) with DTM for TZIDC to CD-ROM

6 Electrical connections

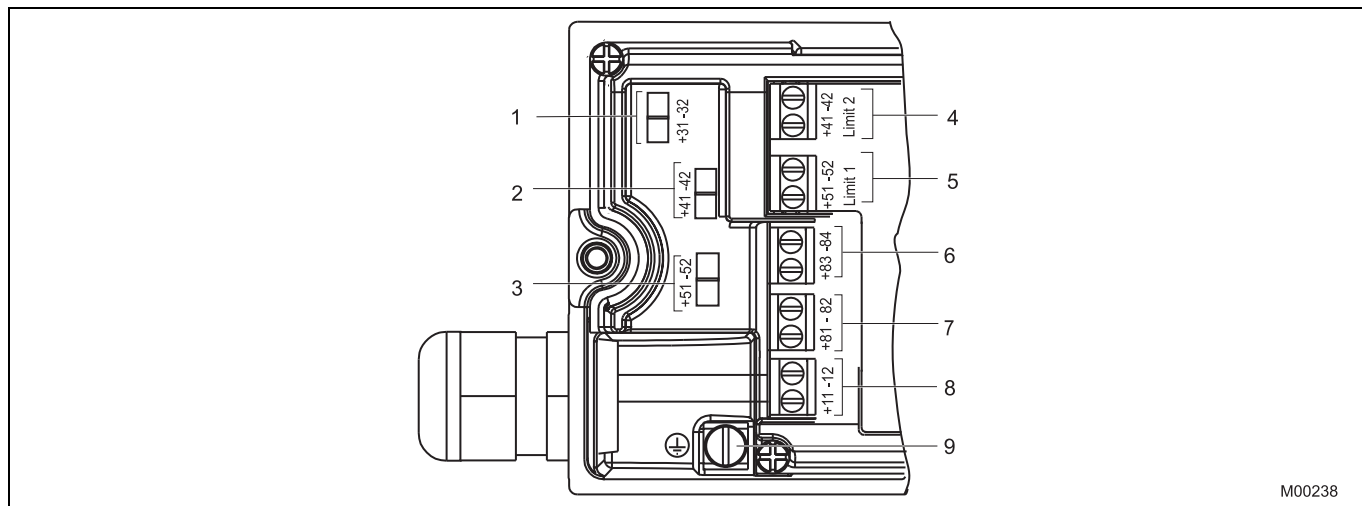

Fig. 7: Screw terminals, overview

- | | |
|--|--|
| 1 Module for analog position feedback | 5 Digital position feedback, either proximity switches or 24 V microswitches |
| 2 Module for digital feedback or service switch of emergency shutdown module | 6 Digital output DO |
| 3 Module for digital feedback or terminals for emergency shutdown module | 7 Digital input |
| 4 Digital position feedback, either proximity switches or 24 V microswitches | 8 Signal 4 ... 20 mA |
| | 9 Grounding screw |

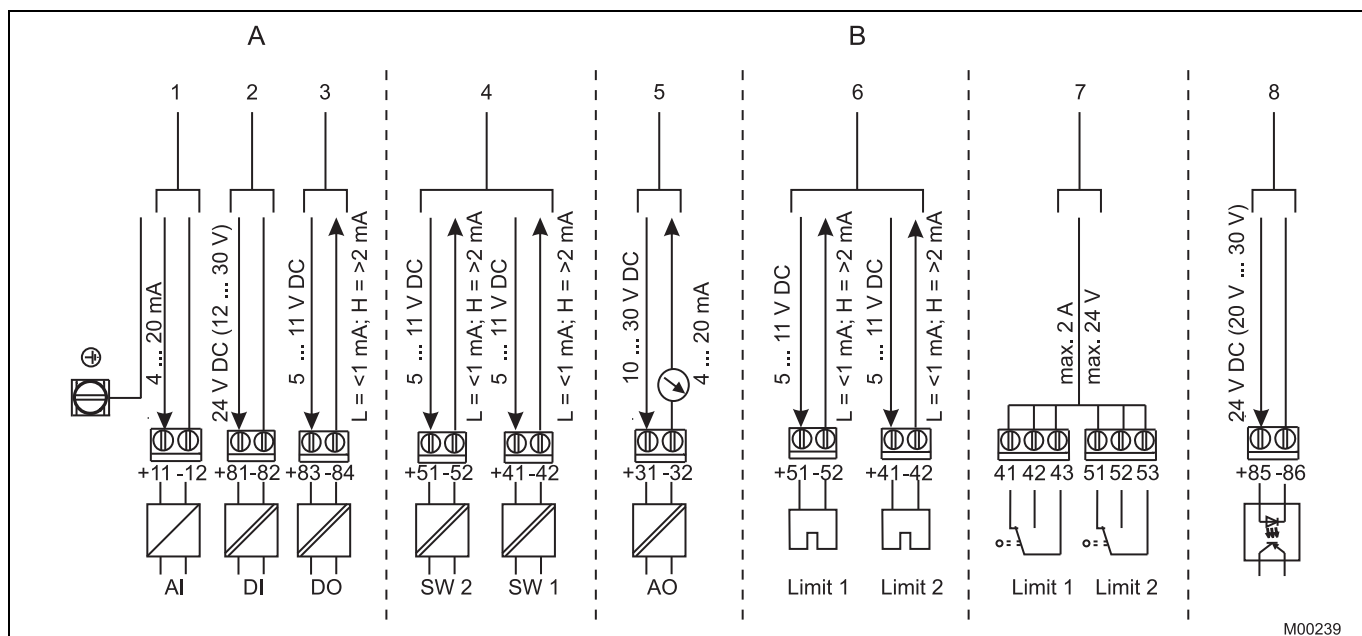

Fig. 8: Pin configuration

- | | |
|---------------|-----------------------------|
| A Basic model | 1 Analog input |
| B Options | 2 Digital input |
| | 3 Digital output DO |
| | 4 Digital feedback |
| | 5 Analog feedback |
| | 6 Proximity switches |
| | 7 Microswitches |
| | 8 Emergency shutdown module |

7 Dimensions

All dimensions in mm (inch)

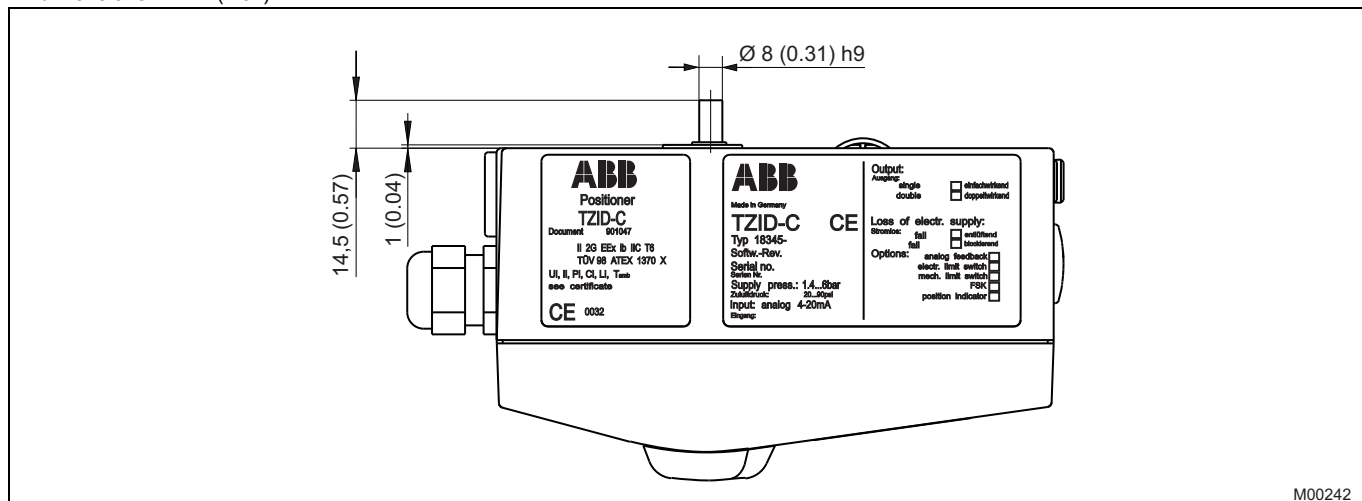

Fig. 9: Top view

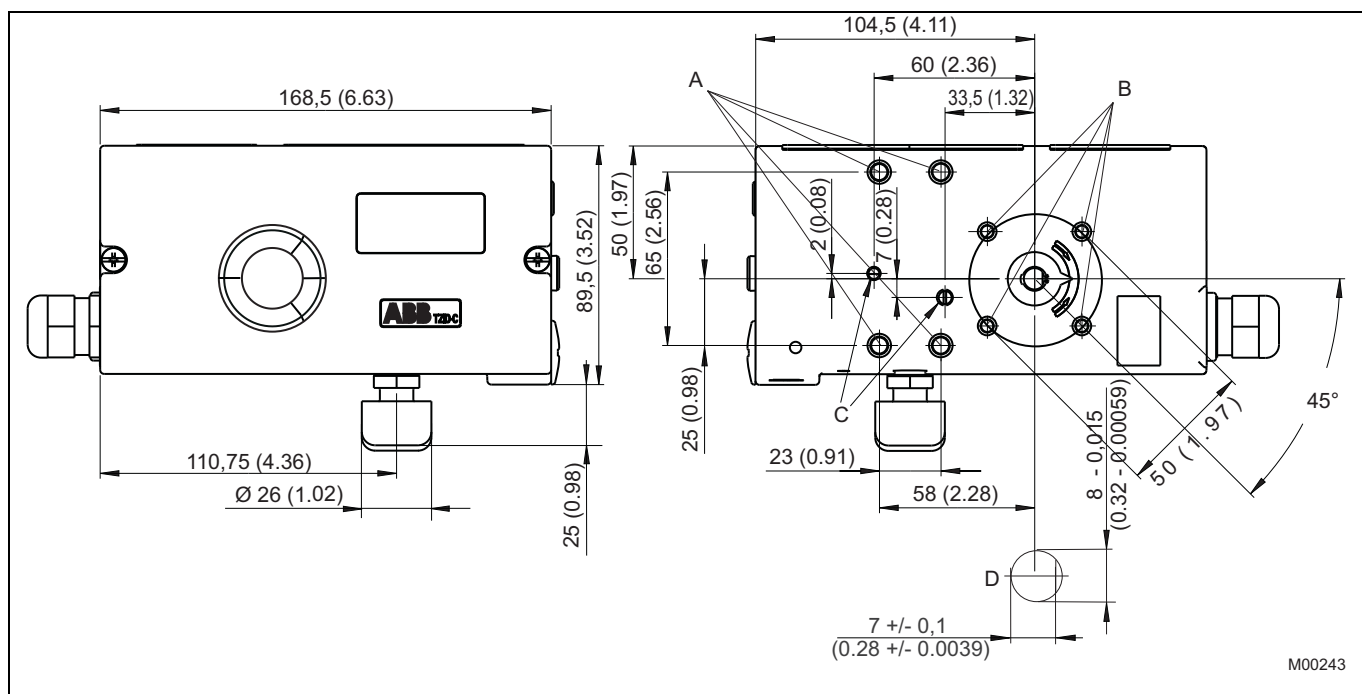
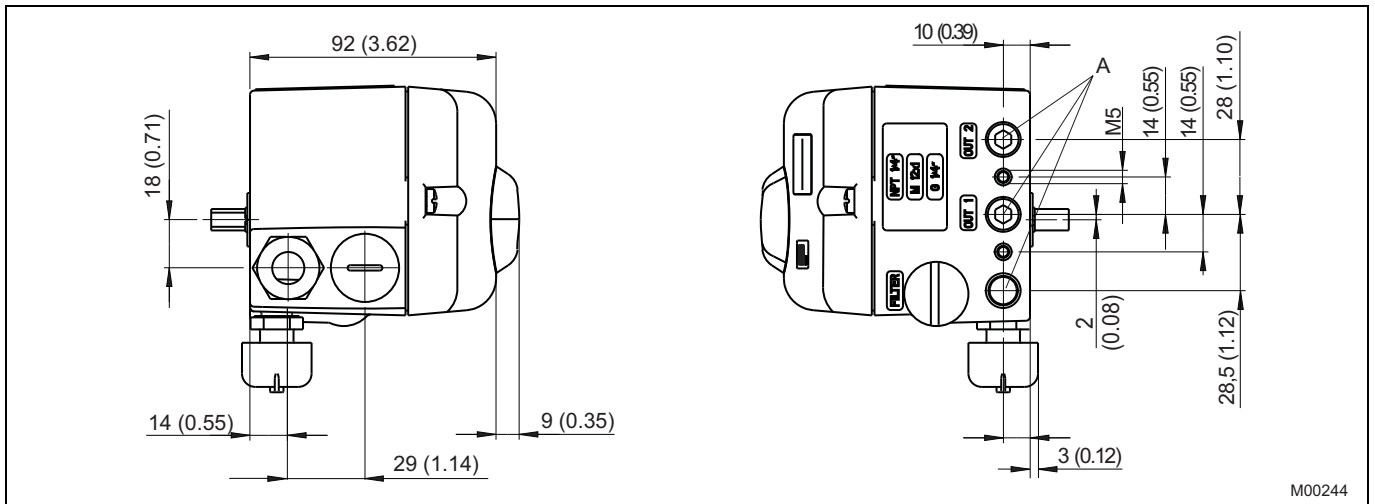

Fig. 10: Front and rear views

- A Tap hole M8 (10 mm low)
- B Tap hole M6 (8 mm low)

- C Tap hole M5 x 0.5 (air vents for direct mount)
- D Sensor shaft (larger than scale)



M00244

Fig. 11: side view (from left to right)
A Pneumatic connections, NPT 1/4"-18 or G1/4"

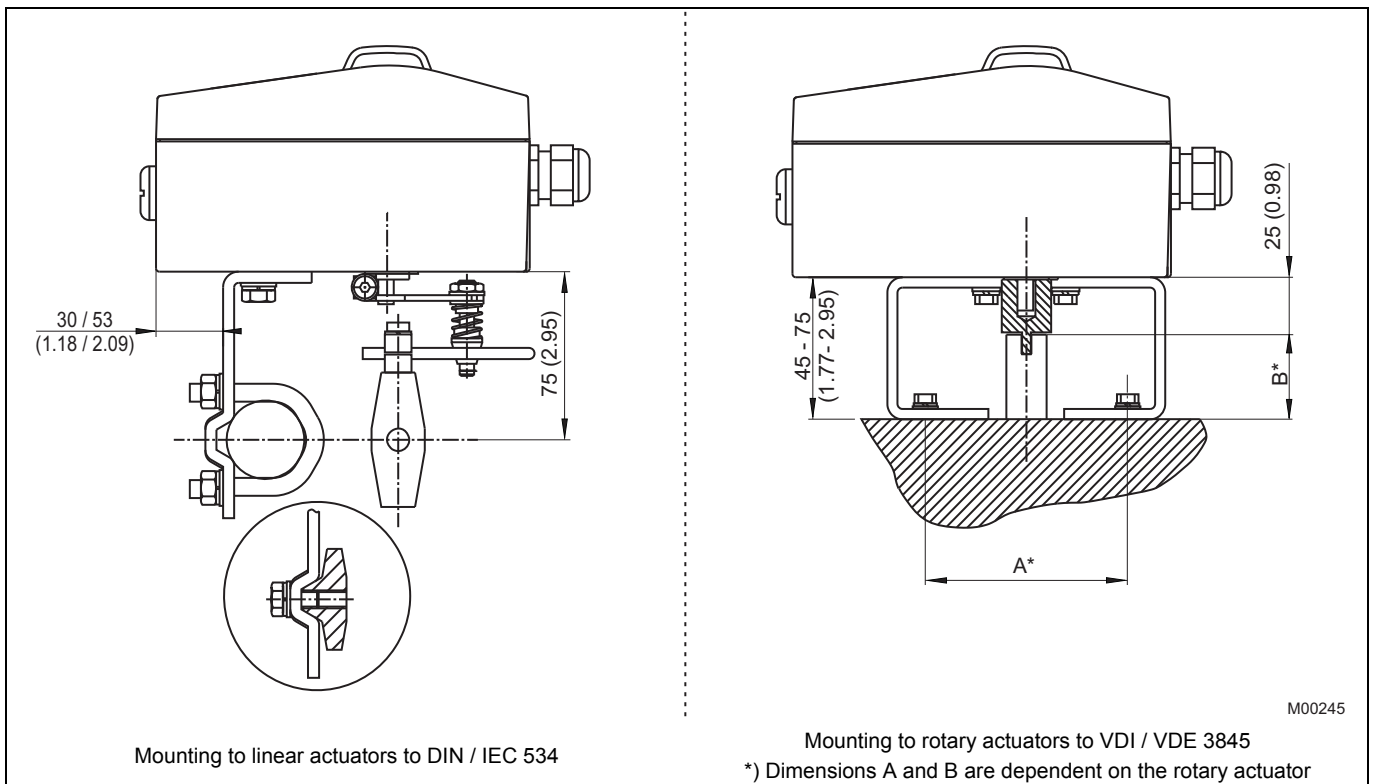

M00245

Fig. 12: Mounting drawings

Mounting to linear actuators to DIN / IEC 534
Mounting to rotary actuators to VDI / VDE 3845
*) Dimensions A and B are dependent on the rotary actuator

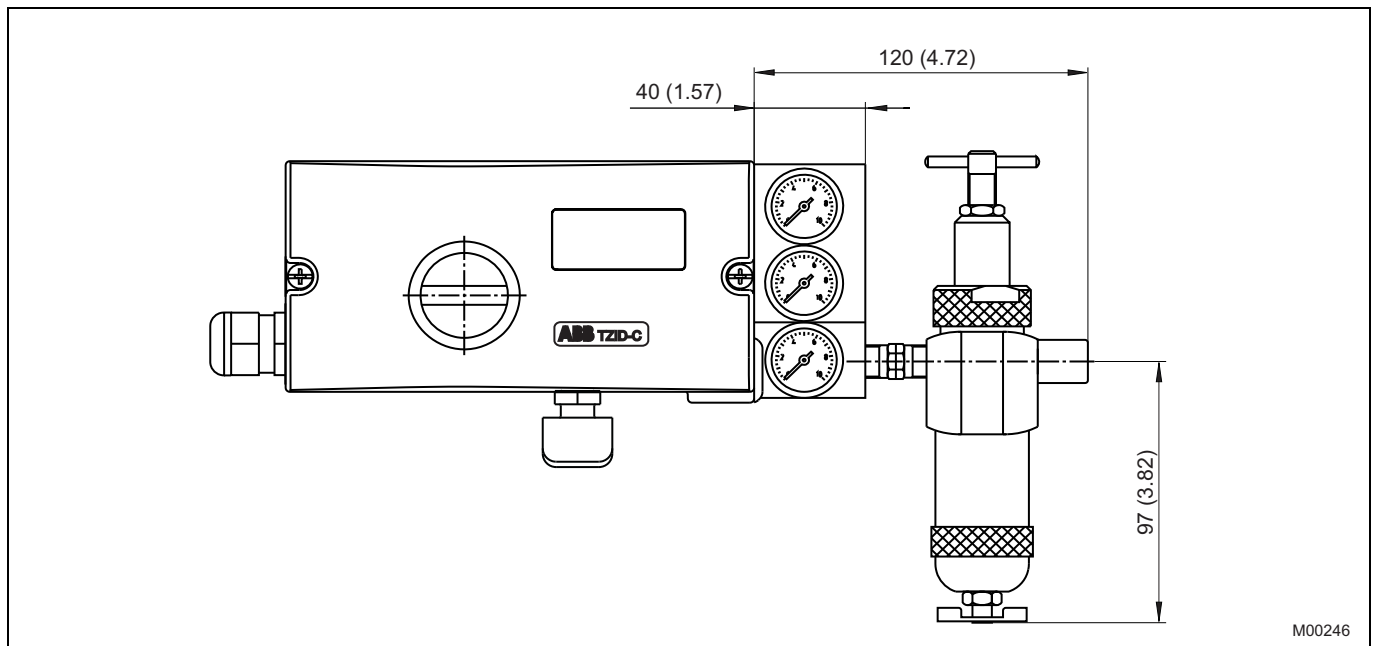

Fig. 13: Positioner with pressure gauge block and filter regulator

8 Ordering information

	Main Code																Add. Code
	Variant digit No.	1 - 6	7	8	9	10	11	12	13	14	15	16	XX				
TZIDC Electro-Pneumatic Positioner, intelligent, configurable, with indicator and operator panel	V18345		X	X	X	X	X	X	X	X	X	X	X	X	X	XX	
Case / Mounting																	
Case made of aluminium, varnished, for mounting to linear actuators acc. DIN/IEC 534 / NAMUR or to rotary actuators acc. VDI/VDE 3845			1	0													
Case made of aluminium, varnished, with mechanical position indicator, for mounting to linear actuators acc. DIN/IEC 534 / NAMUR or to rotary actuators acc. VDI/VDE 3845			2	0													
Case made of aluminium, varnished, for integral mounting to control valves			3	0													
Case made of aluminium, varnished, with mechanical position indicator, for integral mounting to control valves			4	0													
Case made of aluminium, varnished, for mounting to rotary actuators acc. VDI/VDE 3845 with extended rotation angle up to 270°			5	0													
Case made of aluminium, varnished, with mechanical position indicator, for mounting to rotary actuators acc. VDI/VDE 3845 with extended rotation angle up to 270°			6	0													
Input / Communication Port																	
Input 4 ... 20 mA, two-wire, with connector plug for LKS adapter						1											
Input 4 ... 20 mA, two-wire, with connector plug for LKS adapter and FSK module for HART communication						2											
Explosion Protection																	
Without						0											
ATEX Ex II 2 G EEx ib II C T6						1											
FM/CSA						2											
ATEX EEx n A II T6						4											
IECEX Ex ib IIC T6						5											
IECEX Ex nA II T6						6											
ATEX Ex II 2 G EEx ia II C T6						7											
ATEX II 2D IP6X T 51 °C (Zone 21)						8											
GOST Russia Ex II 2 G EEx ib II C T6						B											
GOST Russia EEx n A II T6						C											
Output / Safe Position (in case of an electrical power failure)																	
Single acting, fail safe										1							
Single acting, fail freeze										2							
Double acting, fail safe										4							
Double acting, fail freeze										5							
Connections																	
Cable: Thread 1/2-14 NPT, air pipe: Thread 1/4-18 NPT										2							
Cable: Thread M20 x 1.5, air pipe: Thread 1/4-18 NPT										5							
Cable: Thread M20 x 1.5, air pipe: Thread G 1/4										6							

Continued on next page

	Main Code.													Add. Code				
	Variant digit No.	1	2	3	4	5	6	7	8	9	10	11	12		13	14	15	16
TZIDC Electro-Pneumatic Positioner, intelligent, configurable, with indicator and operator panel	V18345	X	X	X	X	X	X	X	X	X	X	X	X	X	X	X	X	XX
Option Modules for Analog or Digital Position Feedback																		
Without																		0
Plug-in module for analog position feedback, signal range 4 ... 20 mA, two-wire																		1
Plug-in module for digital position feedback																		3
Plug-in module for shutdown function																	1)	4
Plug-in module for analog position feedback, signal range 4 ... 20 mA, two-wire, and digital position feedback																		5
Plug-in module for analog position feedback, signal range 4 ... 20 mA, two-wire, and shutdown module																	1)	6
Plug-in module for analog position feedback, 48 V DC																	2)	7
Optional mechanical kit for digital position feedback																		
Without																		0
Mechanical kit for digital position feedback with proximity switches SJ2-SN (NC or logical 1)																		3)
Mechanical kit for digital position feedback with proximity switches SJ2-S1N (NO or logical 0)																		4)
Mechanical kit for digital position feedback with 24 V AC / DC microswitches (change-over contacts)																		5)
Design (Varnish / Coding)																		
Standard																		1
Special version for Chemical Industries																		6)
Protection Class IP 66 / NEMA 4X																		P
SIL2 - Declaration of Conformity																		
SIL2 - Declaration of Conformity																		7)
Certificate of Compliance																		
Certificate of compliance with the order acc. EN 10204-2.1 (DIN 50049-2.1)																		
Certificate of compliance with the order acc. EN 10204-2.1 (DIN 50049-2.1) with item description																		
Test report acc. EN 10204-2.2 (DIN 50049-2.2)																		
Inspection Certificate																		
Inspection certificate 3.1 acc. EN 10204																		
Device Identification Label																		
Stainless steel 11.5 x 60 mm (0.45 x 2.36 in.)																		
Sticker 11 x 25 mm (0.43 x 0.98 in.)																		

- 1) Only for fail safe pneumatic. Not for FM / CSA Version
- 2) Not for explosion protected version
- 3) Only for model with mechanical position indicator
- 4) Only for model with mechanical position indicator and only for ambient temperature range -25 ... 85 °C
- 5) Not for explosion protected version and only for model with mechanical position indicator
- 6) (Details on request)
- 7) With single acting, fail safe pneumatic only

Accessories	Order number
TZIDC Mounting bracket	
TZIDC Mounting bracket for rotary actuators (mounting to VDI / VDE 3845), dimension A/B = 80/20 mm	319603
TZIDC Mounting bracket for rotary actuators (mounting to VDI / VDE 3845), dimension A/B = 80/30 mm	319604
TZIDC Mounting bracket for rotary actuators (mounting to VDI / VDE 3845), dimension A/B = 130/30 mm	319605
TZIDC Mounting bracket for rotary actuators (mounting to VDI / VDE 3845), dimension A/B = 130/50 mm	319606
TZIDC Attachment kit for linear actuators	
TZIDC Attachment kit for linear actuators, stroke 10 ... 35 mm	7959125
TZIDC Attachment kit for linear actuators, stroke 20 ... 100 mm	7959126
TZIDC Lever	
TZIDC Lever 30 mm	7959151
TZIDC Lever 100 mm	7959152
TZIDC Adapter	
TZIDC Adapter (shaft coupler) for rotary actuators (mounting to VDI / VDE 3845)	7959110
TZIDC Pressure gauge block	
TZIDC Pressure gauge block, for single acting TZIDC, 0 ... 6 bar (0 ... 90 psi), G 1/4 connections	7959111
TZIDC Pressure gauge block, for single acting TZIDC, 0 ... 10 bar (0 ... 140 psi), G 1/4 connections	7959112
TZIDC Pressure gauge block, 0.6 MPa, single acting, G 1/4 connection	7959364
TZIDC Pressure gauge block, 0.6 MPa, single acting, Rc 1/4 connection	7959358
TZIDC Pressure gauge block, 0.6 MPa, single acting, NPT 1/4 connection	7959360
TZIDC Pressure gauge block, for single acting TZIDC, 0 ... 6 bar (0 ... 90 psi), 1/4-18 NPT connections	7959113
TZIDC Pressure gauge block, for single acting TZIDC, 0 ... 10 bar (0 ... 140 psi), 1/4-18 NPT connections	7959114
TZIDC Pressure gauge block, for double acting TZIDC, 0 ... 6 bar (0 ... 90 psi), G 1/4 connections	7959115
TZIDC Pressure gauge block, for double acting TZIDC, 0 ... 10 bar (0 ... 140 psi), G 1/4 connections	7959116
TZIDC Pressure gauge block, 0.6 MPa, double acting, G 1/4 connection	7959365
TZIDC Pressure gauge block, 0.6 MPa, double acting, Rc 1/4 connection	7959359
TZIDC Pressure gauge block, 0.6 MPa, double acting, NPT 1/4 connection	7959361
TZIDC Pressure gauge block, for double acting TZIDC, 0 ... 6 bar (0 ... 90 psi), 1/4-18 NPT connections	7959117
TZIDC Pressure gauge block, for double acting TZIDC, 0 ... 10 bar (0 ... 140 psi), 1/4-18 NPT connections	7959118
TZIDC Filter regulator	
TZIDC Filter regulator, brass, connections thread G 1/4, incl. material for mounting to pressure gauge block	7959119
TZIDC Filter regulator, brass, connections thread 1/4-18 NPT, incl. material for mounting to pressure gauge block	7959120
TZIDC Attachment kit	
TZIDC Attachment kit for Badger Meter ATC 754/755	7959123
TZIDC Attachment kit for Fisher 1051-30, 1052-30	7959214
TZIDC Attachment kit for Fisher 1061 size 130	7959206
TZIDC Attachment kit for Fisher 471	7959195
TZIDC Attachment kit for Fisher 585 C	7959250
TZIDC Attachment kit for Fisher 657 / 667 Size 10 ... 30 mm	7959177
TZIDC Attachment kit for GEMÜ 690/25 and 50	7959103
TZIDC Attachment kit for Gulde DK	7959161
TZIDC Attachment kit for Keystone 79U/E-002(S) ... 79U/E-181(S)	7959147
TZIDC Mounting kit Koso short lever	7959362
TZIDC Mounting kit Koso long lever	7959363
TZIDC Attachment kit for Masoneilan CAMFLEX II, VARIMAX, MINITORK II	7959144
TZIDC Attachment kit for Masoneilan VariPak 28000 series	7959163
TZIDC Attachment kit for MaxFlo MaxFlo	7959140
TZIDC Attachment kit for NAF 791290	7959207
TZIDC Attachment kit for NAMUR stroke 100 ... 170 mm	7959339
TZIDC Attachment kit for NELES BC6-20, B1C6-20, BJ8-20, B1J8-20	7959146
TZIDC Attachment kit for Valves Nuovo Pignone, lever for linear stroke, length 150 ... 250 mm	7959210
TZIDC Attachment kit for Valves Nuovo Pignone, pressure gauge block with 2 manometers, material stainless steel	7959181
TZIDC Attachment kit for Samson 241, 271, 3271	7959145
TZIDC Attachment kit for Samson 3277	7959136
TZIDC Attachment kit for Schubert&Salzer GS 8020 / 8021 / 8023	7959200
TZIDC Attachment kit for SED SED stroke 100 mm	7959141

ABB has Sales & Customer Support expertise in over 100 countries worldwide.

www.abb.com/instrumentation

The Company's policy is one of continuous product improvement and the right is reserved to modify the information contained herein without notice.

Printed in the Fed. Rep. of Germany (09.2010)

© ABB 2010

3KXE341001R1001



ABB Limited

Salterbeck Trading Estate
Workington, Cumbria
CA14 5DS
UK
Tel: +44 (0)1946 830 611
Fax: +44 (0)1946 832 661

ABB Inc.

125 E. County Line Road
Warminster, PA 18974
USA
Tel: +1 215 674 6000
Fax: +1 215 674 7183

ABB Automation Products GmbH

Schillerstr. 72
32425 Minden
Germany
Tel: +49 551 905-534
Fax: +49 551 905-555